

Collamat® Flexoline

The Collamat® Flexoline Side-Conveyor using a wrap around unit creates new possibilities for labelling cylindrical products of all sizes. The sleek design permits a minimum distance to the base conveyor, allowing products of low height to be handled. Encoder control and variable speed settings optimise the labelling process. A cellular rubber belt absorbs large variations in product diameter. The unit firmly presses labels onto an uneven product and achieves better durability. The Collamat® Flexoline concept allows easy integration to existing lines and guarantees long-term reliability.

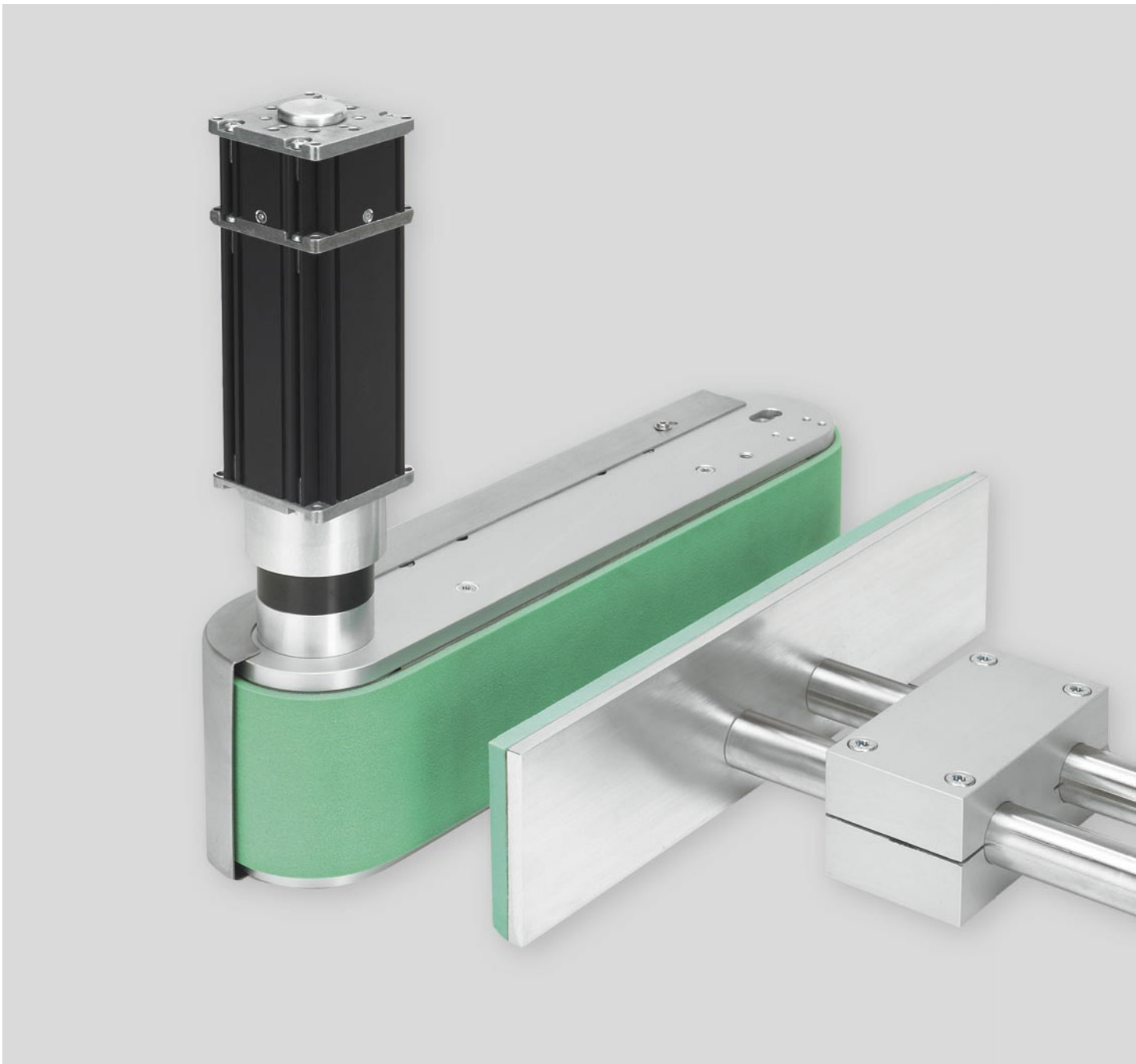



FEATURES

- All-round side belt – Usable as wrap around or transfer unit between conveyors or for bottom marking/labelling
- Variable speed – The ratio between wrap speed and product linear speed is variable
- Synchronized speed – The speed of the servo motor can be synchronized with the conveyor by an encoder
- Various belt heights – Suitable for small or tall products
- Cellular rubber belt – To optimise hold and pressure on the product and prevent damage
- Safety – To prevent injury, the power consumption and the direction of rotation is adjustable

TECHNICAL DATA

Max product speed:	35 m/min. (Max wrap speed: 70 m/min)
Length:	300 mm (shaft centres)
Belt width:	40, 100, 160 (Other widths on request)
Speed synchronisation:	Automatic measurement by encoder, or optional fix speed
Parameterisation:	Speed, drive direction, power consumption via PC or Internet
Conveyor belt :	5 mm thick cellular rubber belt
Drive unit:	Servo motor (Collamat firmware)
Power supply:	24V DC
Communication:	CANopen
Options:	Height adjustment unit, Product scanner, 24V power supply unit, Encoder (CAN-Bus), CAN-Bus wiring
Approbation:	CE/Gost

All data are indicative and may be subject to alteration

©2006 - All IPR's belong to HM Group

HM Collamat AG
Pfeffingerring 201
CH-4147 Aesch

Phone: +41 (0)61 756 28 28
Fax: +41 (0)61 756 29 29
Web: www.collamat.ch
E-mail: contact@collamat.ch

Member of HM Group

